

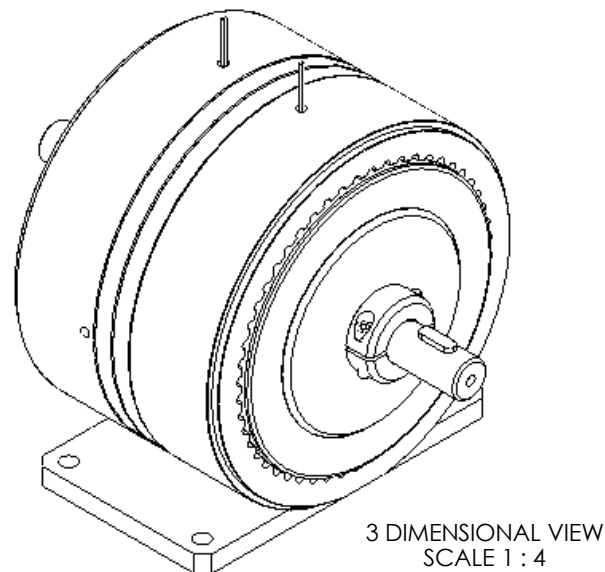

SOLID MODEL AVAILABLE

MODEL	COIL NUMBER	STOCK CODE	MINIMUM TORQUE AT RATED CURRENT (Nm)	RATED CURRENT (mA)	RESISTANCE ±10% @ 25°C (ohms)	VOLTAGE (Vdc)	NOMINAL POWER (watts)	MAXIMUM SPEED (RPM)	KINETIC POWER RATINGS		DE-ENERGIZED DRAG TORQUE @ 1000 RPM (Nm)	EXTERNAL INERTIA (kg cm ²)	ANGULAR ACCELERATION (rad/s ²)
									5 MINUTE (watts)	CONTINUOUS (watts)			
HB-3500M	-1 (90 Vdc)	-	-	-	-	-	-	6,000	2,400	600	1.36 X 10 ⁻¹	1.25 X 10 ²	2,070
	-2 (24 Vdc)	004303	24.72	1000	26	26	26						
	-3 (12 Vdc)	-	-	-	-	-	-						

26 Nm IS ATTAINABLE @ APPROXIMATELY 1200 mA

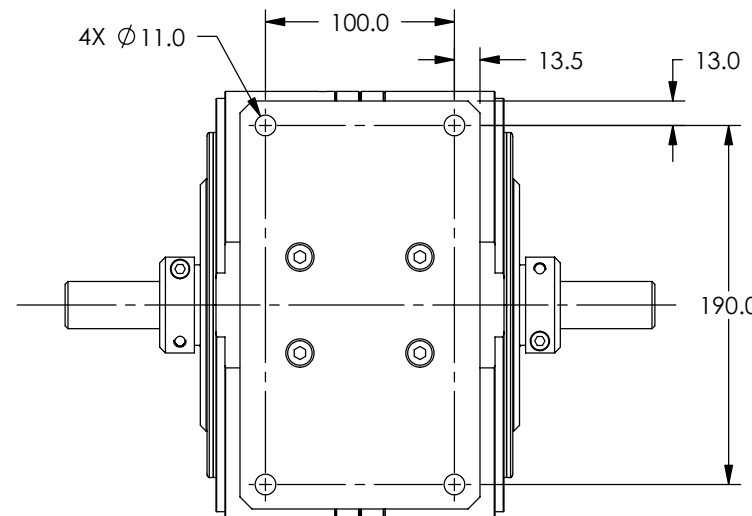
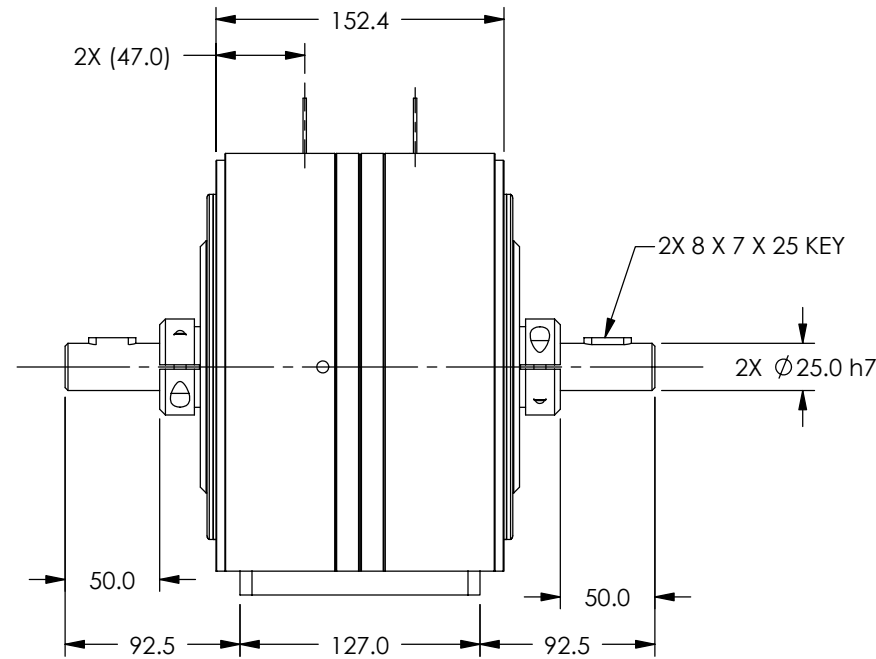
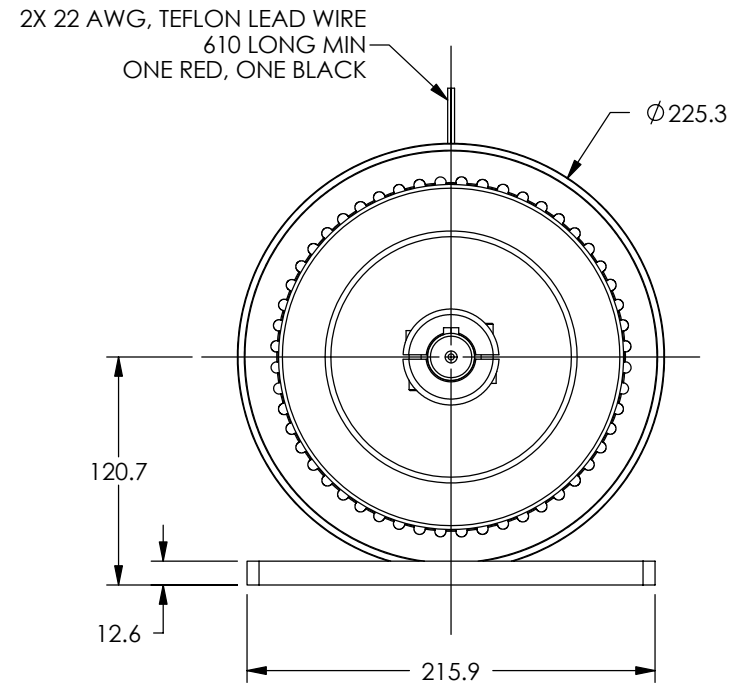

MATERIAL:	DESIGN	-	-	 MAGTROL INC. 70 GARDENVILLE PKWY, W. BUFFALO, NEW YORK 14224-1322	
FINISH:	DRAWN	AJC	01/27/04		
THIRD ANGLE PROJECTION	CHECKED	DTW	01/27/04	TITLE	
THIS DRAWING AND SPECIFICATION CONTAINS PROPRIETARY INFORMATION TO MAGTROL INC. ANY DISCLOSURE OR REPRODUCTION OF THIS DOCUMENT WITHOUT WRITTEN AUTHORIZATION FROM MAGTROL INC. IS EXPRESSLY PROHIBITED	UNLESS OTHERWISE SPECIFIED: DIMENSIONS ARE IN MILLIMETERS, DIAMETERS CONCENTRIC: .08 TIR, FACES PERPENDICULAR: .08 INTERPRETATION PER ASME Y14.5M-1994 REMOVE ALL BURRS AND BREAK SHARP EDGES .13/.25 X 45°, ALL INSIDE CORNERS TO BE .5 R MAX. TOLERANCES: X ± .4 .XX ± .13 .X ± .25 ANG. ± 1° SURFACE FINISH 3.2 μm MAX. U.O.S.			HB-3500M, METRIC HYSTERESIS BRAKE	
	USED ON: - SIMILAR TO: -			DWG. NO. HB-3500M	REV A
	SIZE B	SCALE 1:4	SHEET # 2 OF 2		