

THE INFORMATION DISCLOSED HEREIN WAS ORIGINATED BY AND IS THE PROPERTY OF MAGTROL SA. MAGTROL SA RESERVES ALL PATENT PROPRIETARY, DESIGN, USE, SALE, MANUFACTURING AND REPRODUCTION RIGHTS THERETO.

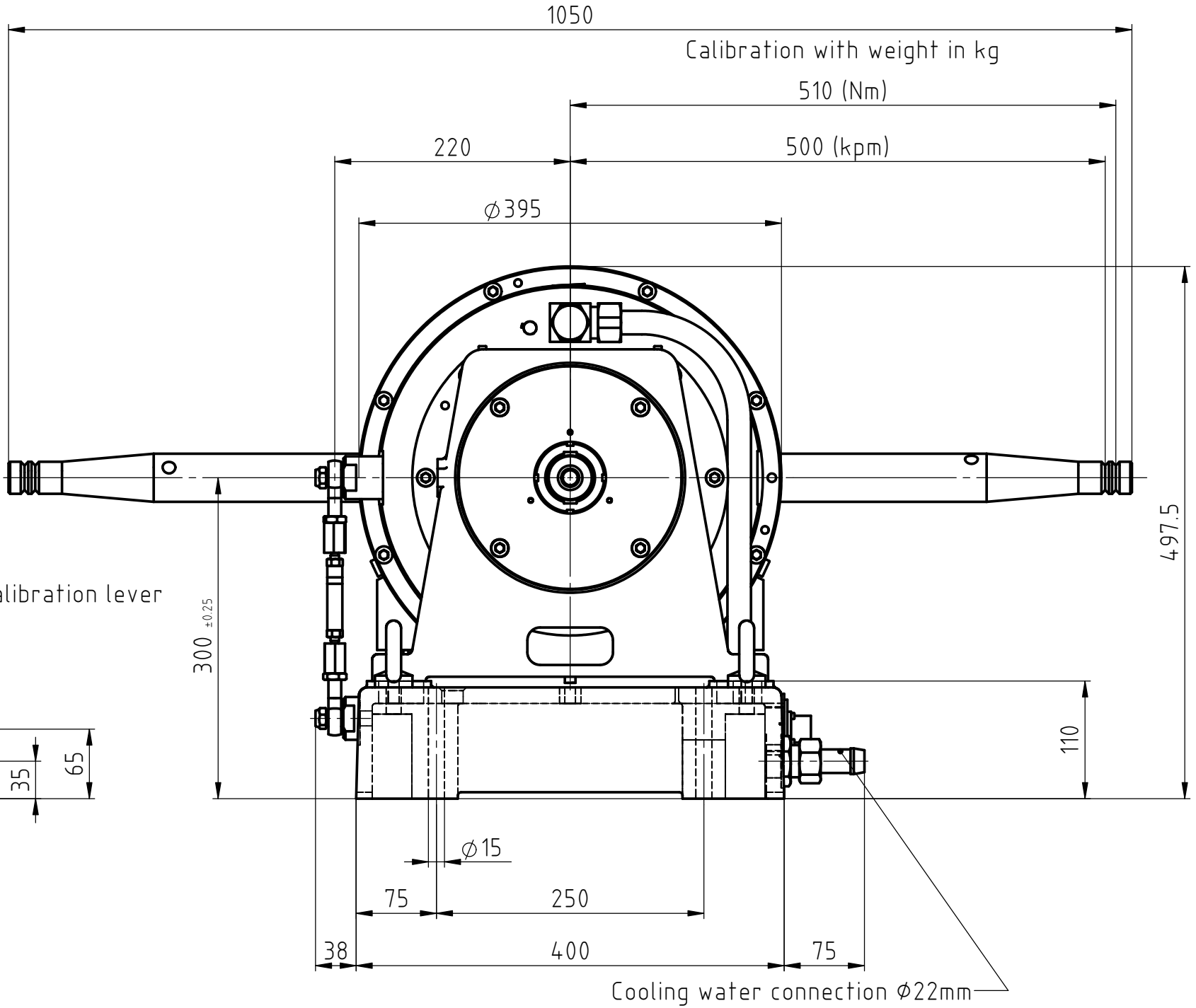
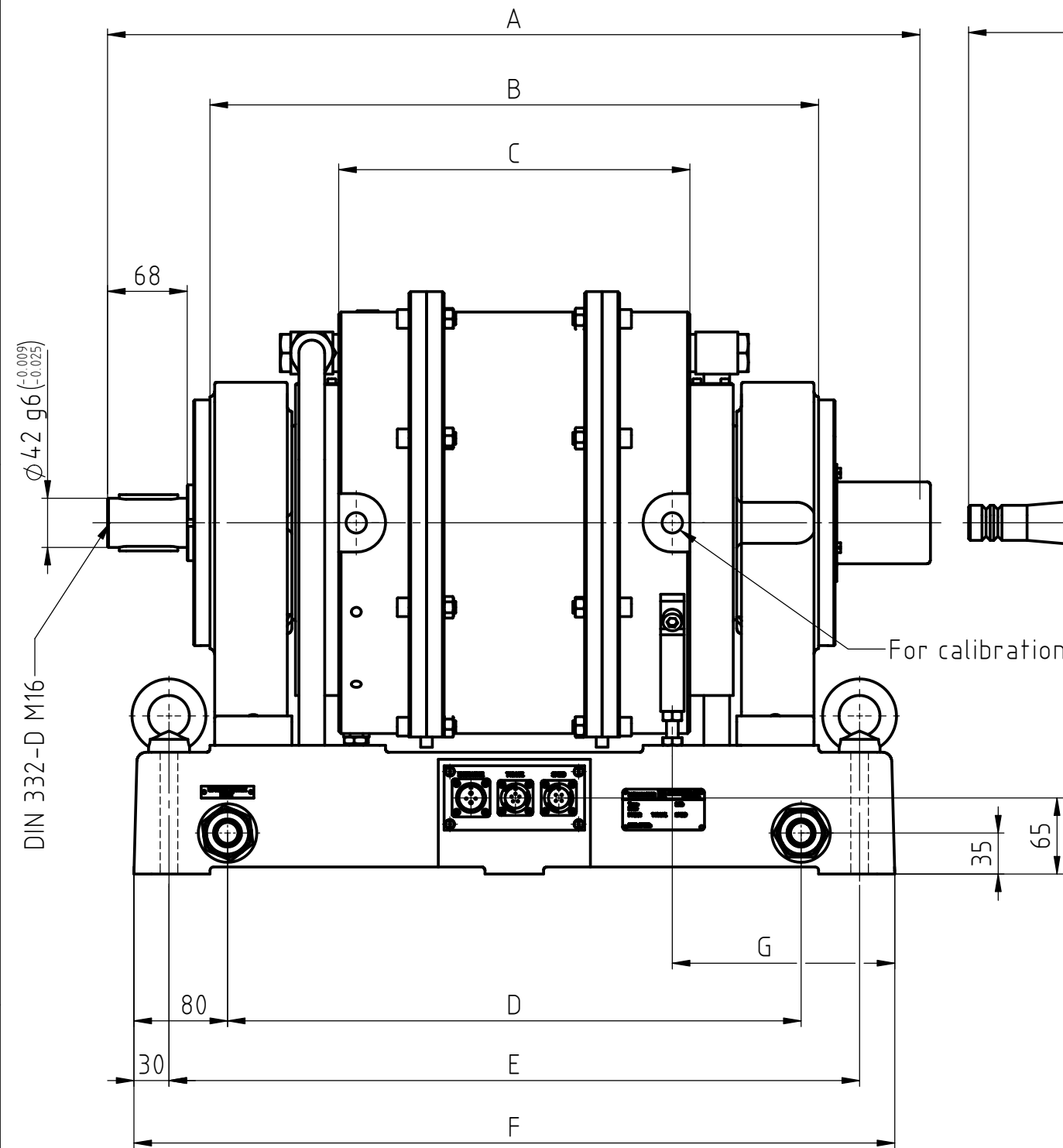

Type	A	B	C	D	E	F	G	H
1WB 15 / 1PB 15	544	370	150	490	590	650	265	-53
2WB 15 / 2PB 15	694	520	300	490	590	650	190	22
3WB 15 / -----	844	670	450	840	940	1000	290	-78
4WB 15 / 4PB 15	994	820	600	840	940	1000	215	-3

6																	
5																	
4																	
3																	
2																	
1																	
Rev.	Date	PM	Drawn	Appr.	Repl. by :												
					Repl. for: VZB 100-900												
Tolerances: \pm mm to 50mm, \pm mm over 50mm																	
Material:						Scale 1:5		<table border="1"> <tr> <td>Drawn</td> <td>03.04.97</td> <td>A.Rappo</td> </tr> <tr> <td>Checked</td> <td></td> <td></td> </tr> <tr> <td>Approved</td> <td></td> <td></td> </tr> </table>	Drawn	03.04.97	A.Rappo	Checked			Approved		
Drawn	03.04.97	A.Rappo															
Checked																	
Approved																	
Finish:						DRAWING N°											
<p style="text-align: center;">Dynamometers</p> <p style="text-align: center;">1-4WB15 1-4PB15</p>						<p style="text-align: center;">314-101-000V011</p>											

A

B

C

D