

AC89@	7C@ BIA69F fL	GC7? 7C89	A-B-AIA HCFE195H F5H8 71FF9BH fà Ba t	F5H8 71FF9BH fà 5t	F9G5B79 -% 4 & S7 ft\ a g	JC@5; 9 fJ XVL	BCA-B5@ DCK 9F fk Uhtg	A5L-AIA GD998 fFDA t	?-B9H7 DCK 9F F5HB; G	B-DI H G<5: H B9FH5 fL['Wà & t	C I H D I H G<5: H B9FH5 fL['Wà & t	GC@8'A C 89@5J 5-66@
<7:!, A IL	!%f\$J XVL	!)*)	!	!	!	!	'Z\$\$	*\$	%	"&-	"\$')
	!&fB('J XVL	\$\$**'+		%\$	%\$	&+	("\$(
	!'fB&J XVL	!		!	!	!	!					

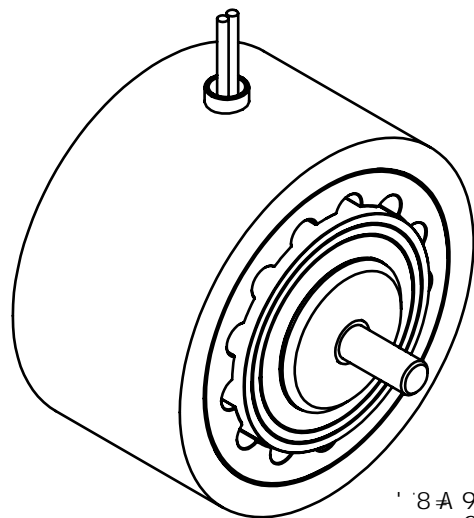
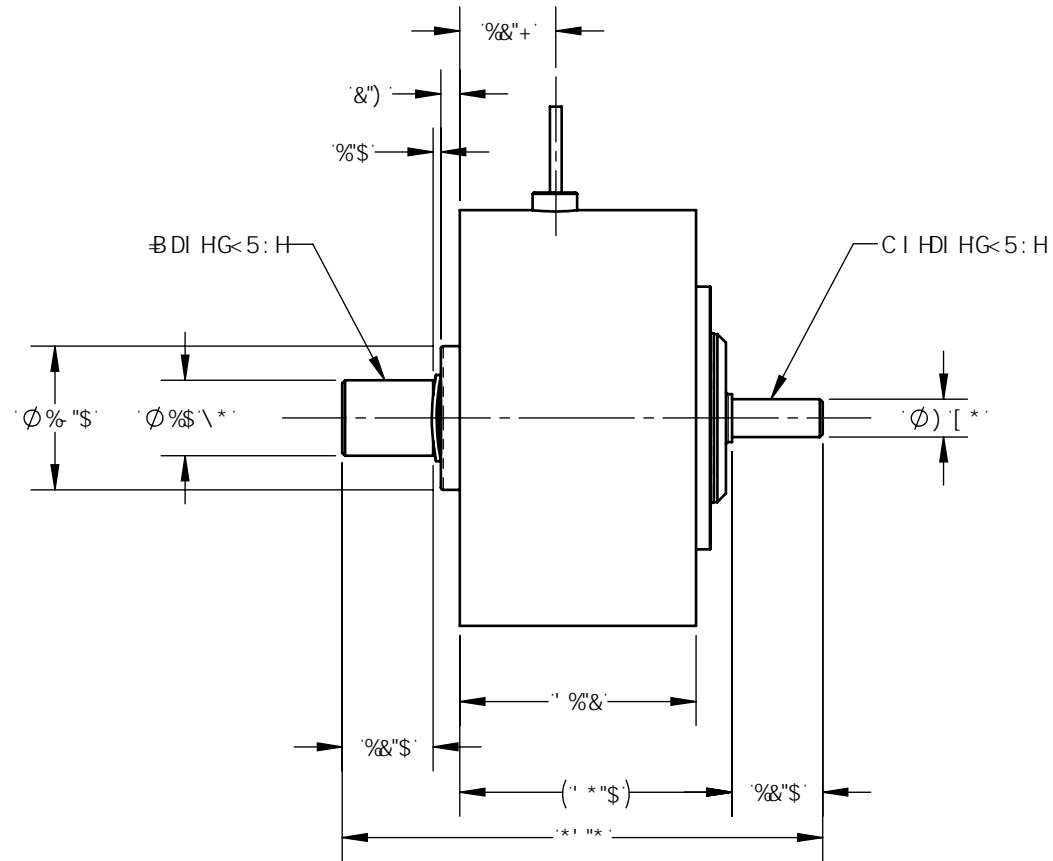
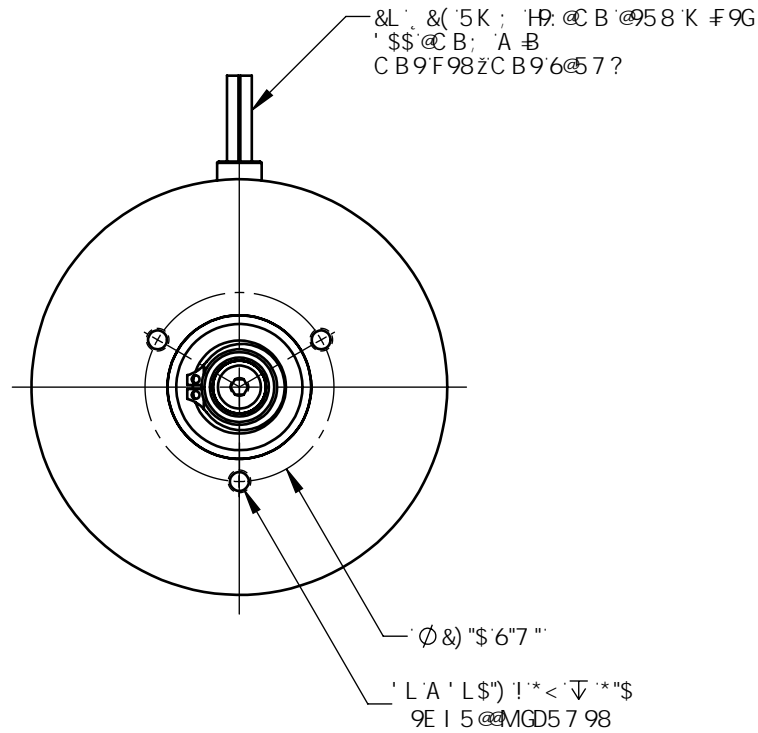

' 8-A 9B G@ B 5 @ J -9K
G7 5 @9%%

BG5@5HC B 8F5K B;

A 5Hf-5@	!	89G= B	5>7	%\$#% #*\$		A 5; HFC@B7" +\$; 5F89BJ @@D?K MZK " 6l : : 5@ZB9K 'MCF? '%&&(!% &&
:B-G<	!	8F5K B	5>7	*\$#-\$#\$		
	!	7<97?98	!	!	<7:!, A <MGH9F9G-G'7 @ H7 <	
H<F8 5B; @ DFC >97 HC B		I B @GGC H: 9FK @9GD97 = 98. 8-A 9B G@ B G5F9-B B7 < 9G 8-5A 9HFG7 C B 7 9H F 7. "\$\$ ' HF : 57 9G D9F D9B 8 7 I @5F. "\$\$ B H F D F 9 H H C B ' D9F ' 5 GA 9 'M(") A !% - (F 9A C J 9'5 @6l FFG5B8 '6F95? "G<5FD98; 9G "\$\$) # "\$\$ L () S B G B 9 7 C F B 9 F G H C ' 69 F " \$ & A 5 L H C @9F5B7 9G "LL - "\$% L #M - %#* (") "LLL - "\$\$\$ LS - %\$			H#B9. <7:!, A <MGH9F9G-G'7 @ H7 <	
H<G8F5K-B: 5B8 GD97 = 7 5HC B 7C B H 5 B G D F C D F 9 H F M B : C F A 5 H C B H C ' A 5 : H C @ B 7 " " 5 B M 8 @7 @ G I F 9 C F F 9 D F C 8 I 7 H C B ' C : H : G 8 C 7 I A 9 B H K # C I H K F H H 9 B 5 I H C F H 5 H C B : F C A A 5 : H F C @ B 7 " " G 9 L D F 9 G 3 @ M D F C < 6 H 9 8	F 9A C J 9'5 @6l FFG5B8 '6F95? "G<5FD98; 9G "\$\$) # "\$\$ L () S B G B 9 7 C F B 9 F G H C ' 69 F " \$ & A 5 L H C @9F5B7 9G "LL - "\$% L #M - %#* (") "LLL - "\$\$\$ LS - %\$			BK: BC. <7:!, A 6		
		G4F	G7 5@9	G<99H.	6 %%	