

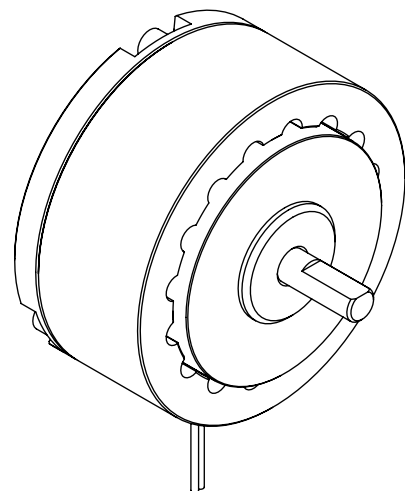

SOLID MODEL AVAILABLE

MODEL	COIL NUMBER	STOCK CODE	MINIMUM TORQUE AT RATED CURRENT (Nm)	RATED CURRENT (mA)	RESISTANCE ±10% @ 25°C (ohms)	VOLTAGE (Vdc)	NOMINAL POWER (watts)	MAXIMUM SPEED (RPM)	KINETIC POWER RATINGS		DE-ENERGIZED DRAG TORQUE @ 1000 RPM (Nm)	EXTERNAL INERTIA (kg cm ²)	ANGULAR ACCELERATION (rad/s ²)
									5 MINUTE (watts)	CONTINUOUS (watts)			
HB-20M	-1 (90 Vdc)	-	0.14	-	-	-	-	20,000	50	12	7.77 X 10 ⁻⁴	4.58 X 10 ⁻²	30,600
	-2 (24 Vdc)	005253	0.14	217	120	26	5.65						
	-3 (12 Vdc)	-	0.14	-	-	-	-						

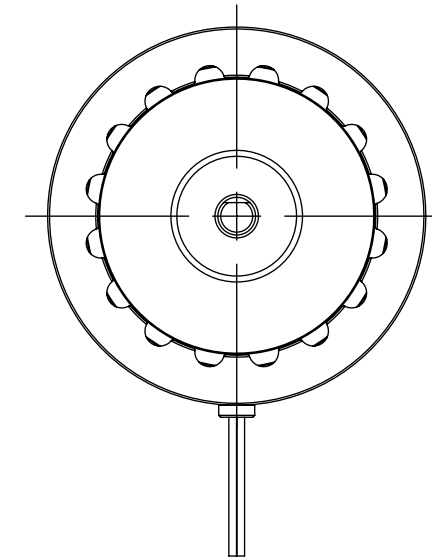
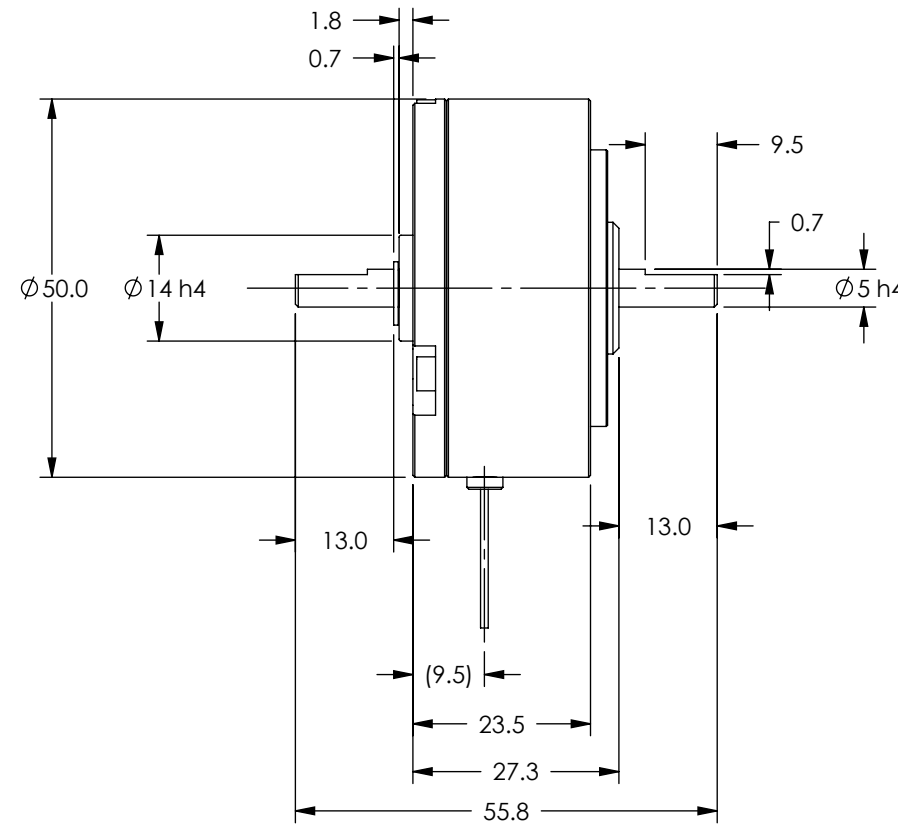
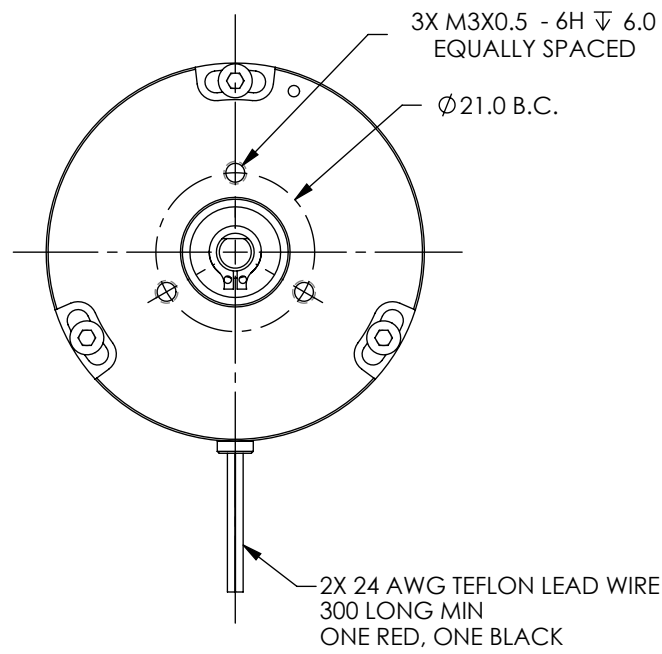

3 DIMENSIONAL VIEW
SCALE 1 : 1

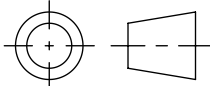
MATERIAL:	DESIGN	AJC	03/26/04	 MAGTROL INC. 70 GARDENVILLE PKWY, W. BUFFALO, NEW YORK 14224-1322
	DRAWN	AJC	03/26/04	
FINISH:	CHECKED	DTW	03/26/04	TITLE HB-20M METRIC HYSTERESIS BRAKE
	THIRD ANGLE PROJECTION 			
UNLESS OTHERWISE SPECIFIED: DIMENSIONS ARE IN MILLIMETERS, DIAMETERS CONCENTRIC: .08 TIR, FACES PERPENDICULAR: .08 INTERPRETATION PER ASME Y14.5M-1994 REMOVE ALL BURRS AND BREAK SHARP EDGES .13/.25 X 45°, ALL INSIDE CORNERS TO BE .5 R MAX. TOLERANCES: X ± .4 .XX ± .13 .X ± .25 ANG. ± 1° SURFACE FINISH 3.2 µm MAX. U.O.S.				USED ON: - SIMILAR TO: 003936
THIS DRAWING AND SPECIFICATION CONTAINS PROPRIETARY INFORMATION TO MAGTROL INC. ANY DISCLOSURE OR REPRODUCTION OF THIS DOCUMENT WITHOUT WRITTEN AUTHORIZATION FROM MAGTROL INC. IS EXPRESSLY PROHIBITED				DWG. NO. HB-20M REV A
SIZE B	SCALE 1:1	SHEET # 2 OF 2		