

AC89@	7C@ BI A 6F fllt	GC7? 7C89	A-B-AIA HCFE195H F5H8 71FF9BH fBa t	F5H8 71FF9BH fBa t	F9G-5B79 -%i 4 & s7 ft\ a g	JC@5; 9 fj XVE	BCA-B5@ DCK 9F fk Ultgt	A5L-AIA GD98 ffDA t	?-B9H7 DCK 9F F5HB; G) A-BIH fk Ultgt	7CBHBI CIG fk Ultgt	899B9F; #98 8F5; HCFE19 4 %\$\$\$FDA fBa t	9LHFB5@ -B9FH5 fll Wa g t	HCFE19HC -B9FH5 F5HC ffUX#g t
<6!%\$A !L	!%fl \$J XVE !&fB(J XVE ! fB&J XVE	\$\$*+) \$\$) &%+ \$\$*+)(\$"\$+	, %' &+\$	% \$\$ % \$ ()	+& &() %&	&"(+ ' "% ' "&	&\$Z\$\$\$	()	%&	+ "\$* L %\$! (") L %\$! %* Z\$\$\$	(") L %\$! %* Z\$\$\$	%* Z\$\$\$

GC @8 'A C 89@5J 5 -@56@

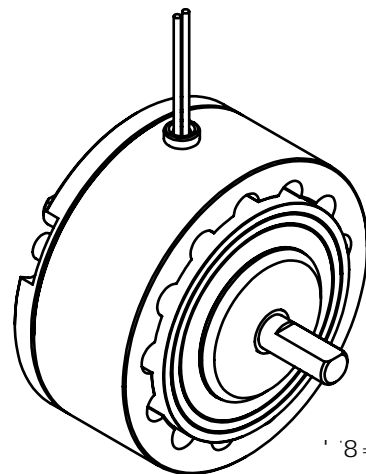
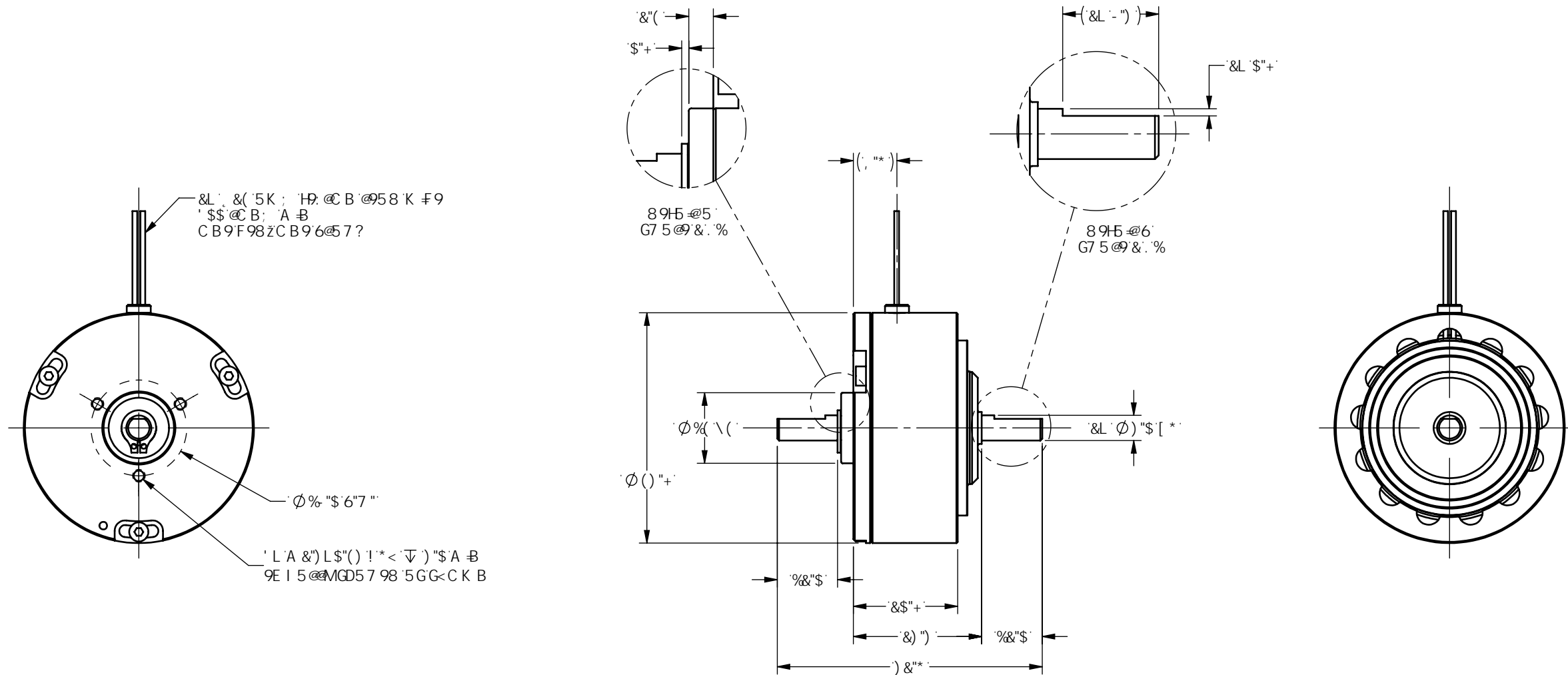

' 8-A 9BG@B5@J -9K
G7 5 @& . %

BG5@5HC B 8F5K B;

A 5HF-5@	89G= B	5>7	\$* #&\$#9%	<p>A 5; HFC@B7" + \$; 5F89BJ @@D?K MZK " 6l : 5@ZB9K 'MCF? %&&(!% &&</p>
! :	8F5K B	5>7	\$* #&\$#9%	
:B-G<	7 < 97 ? 98	>9,	\$+ # \$ * # 9%	<p>I B @GGC H: 9FK @9 GD97 = 98. 8-A 9BG@B5@J -9K 8-5A 9HF G7 C B 7 9H F 7 . "\$, 'HF : 57 9G D9F D9B 8 7 I @5F. "\$, BHF DF 9H5 HC B 'D9F '5 GA 9 'M(") A 1% - () F9A C J 9'5 @6l FFG5B8 '6F 95? 'G<5FD98; 9G\$"% #&\$&) L' () S BGB97 CFB9FGHC '69F '\$") A 5L HC @9F5B7 9G "L - "8) L' - "("LL - "% L S - %& G I : 57 9: B @< " "& @a A 5L</p>
Hk #8 5B; @ DFC >97 HC B				<p>H#89 <MGH9F 9G-G'6F 5 ? 9ZA 9HF =</p>
Hk #8 5B; @ DFC >97 HC B	<p>Hk #8 5B; @ DFC >97 HC B</p>			<p>I 98 CB: ! GA #5F 10: ! BK: BC.</p>
Hk #8 5B; @ DFC >97 HC B	<p>Hk #8 5B; @ DFC >97 HC B</p>			<p><6!%\$A</p>
Hk #8 5B; @ DFC >97 HC B	G4F	G7 5 @9	G<99H.	F9J
Hk #8 5B; @ DFC >97 HC B	6	%%		8