

THE INFORMATION DISCLOSED HEREIN WAS ORIGINATED BY AND IS THE PROPERTY OF MAGTROL SA. MAGTROL SA RESERVES ALL PATENT PROPRIETARY, DESIGN, USE, SALE, MANUFACTURING AND REPRODUCTION RIGHTS THERETO.

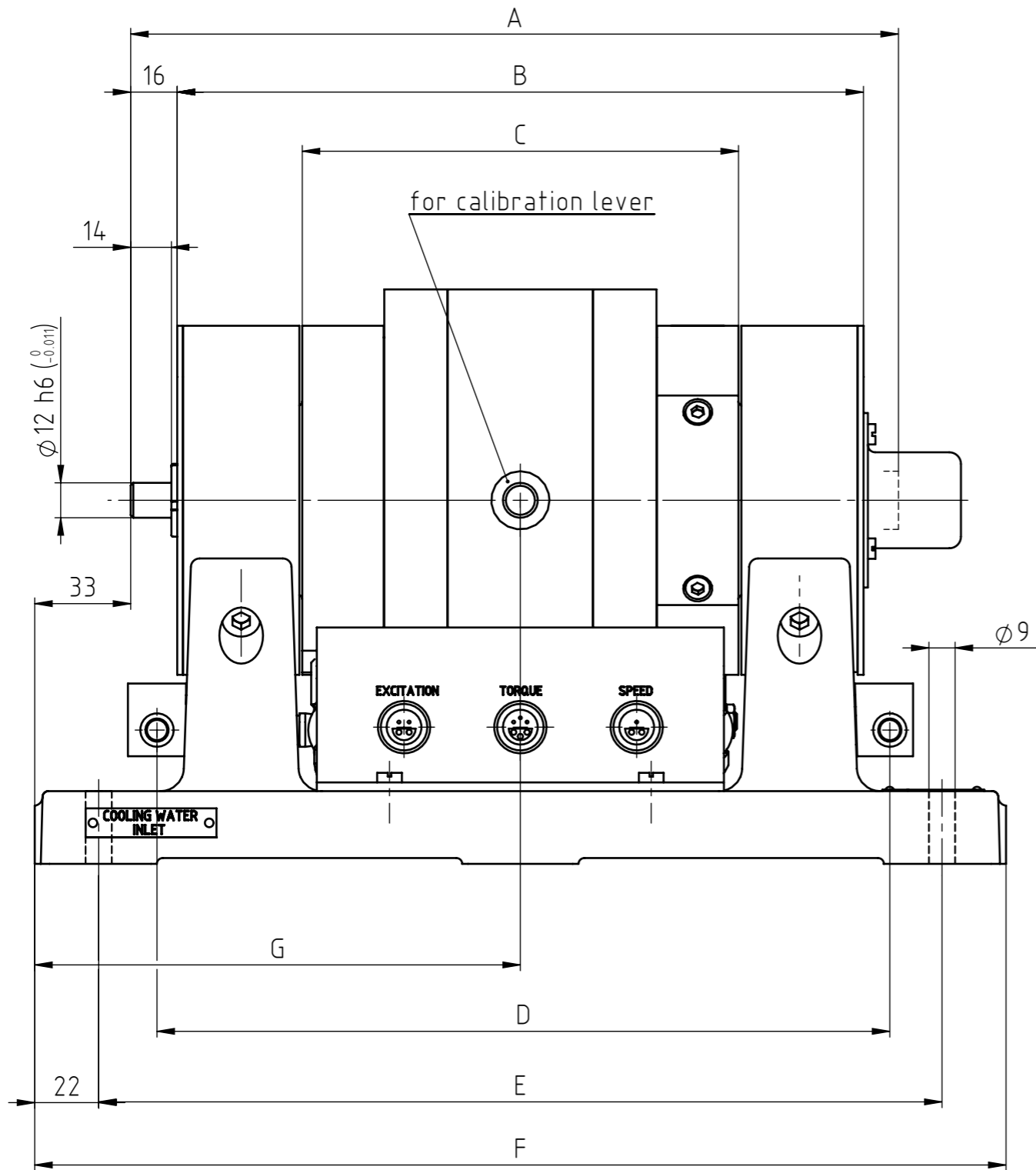

Type	A	B	C	D	E	F	G
1WB43-HS	218	186	100	202	240	284	153
2WB43-HS	268	236	150	252	290	334	167

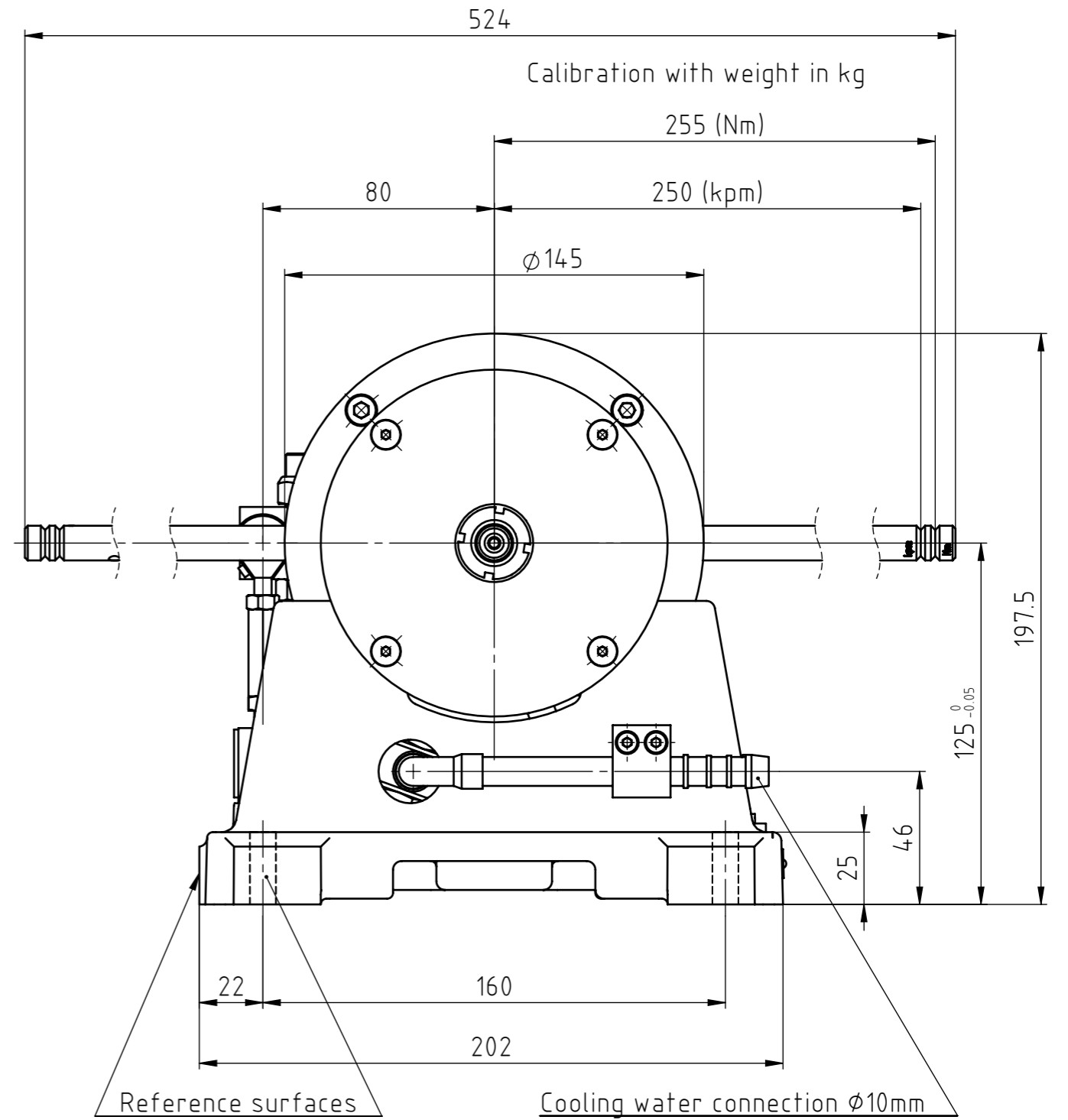

6									
5									
4									
3									
2									
1									
Rev.	Date	PM	Drawn	Appr.	Repl. by :				
					Repl. for :				
Tolerances: $\pm$ . . . mm to 50mm, $\pm$ . . . mm over 50mm									
Material: . . .						Scale		DRAWING N°	
Finish: . . .						1:2		311-211-000V062	
Dynamometers 1+2WB43-HS						Drawn		31.10.2017	
						Checked			
						Approved		31.10.2017	
								ajoy	
								blot	

A

B

C

D